

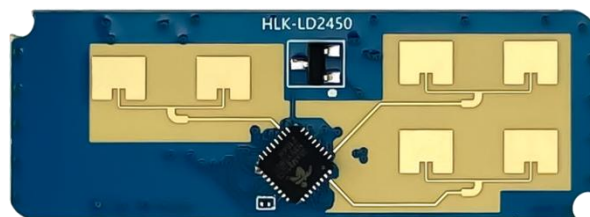

Shenzhen Hi-Link Electronic Co., Ltd.

HLK-LD2450
Motion target detection and
tracking module
Instruction manual



CONTENTS

1 Product overview	4
2 Product features and advantages	5
2.1 Characteristics	5
2.2 Solution advantages	5
3 Application scenarios	7
4 Hardware description	8
4.1 Dimension	8
5 Use and configuration	10
5.1 Typical application circuits	10
5.2 Description of the visualization upper computer	10
6 Communication protocols	12
7 Installation method and detection range	14
7.1 Installation instructions	15
8 Performance and electrical parameters	17
9 Antenna cover design guide	18
9.1 Effect of antenna cover on millimeter wave sensor performance	18
9.2 Antenna cover design principles	18
9.3 Common materials	20
10 Revision record	21
11 Technical support and contact information	22

INDEX OF CHARTS

Table 1	Pin definition table	9
Table 2	Format of reported data frames	12
Table 3	Format of data within the frame	12
Table 4	Table of performance and electrical parameters	17
Table 5	Common material properties of antenna covers	20
Figure 1	Effect of the upper computer function demonstration.....	4
Figure 2	Comparison of millimeter wave radar solutions and other solutions.....	6
Figure 3	Module size diagram.....	8
Figure 4	Module pin definition diagram.....	9
Figure 5	Diagram of wall mounting.....	14
Figure 6	Radar wall mounting angle identification.....	14
Figure 7	Schematic diagram of the tracking range when the radar is wall mounted (wall height 1.5 m).....	14

1 Product overview

Motion target tracking is to track the position of the moving target in the region in real time, and realize the distance, angle and speed measurement of the moving target in the region. The LD2450 is a motion target tracking sensor module from the Hilink 24G millimetre wave radar series, which includes extremely simplified 24 GHz radar sensor hardware and intelligent algorithm firmware. The solution is mainly used in general indoor scenarios such as homes, offices and hotels to enable the location tracking of moving human bodies.

The sensor hardware consists of an AIoT millimetre wave radar chip, a high performance one-transmitter-two-receiver microstrip antenna and a low cost MCU and peripheral auxiliary circuitry. The intelligent algorithm firmware uses FMCW waveforms and the radar chip's proprietary advanced signal processing technology.

It supports serial output of detection data, which is plug-and-play and can be flexibly applied to different smart scenarios and end products.

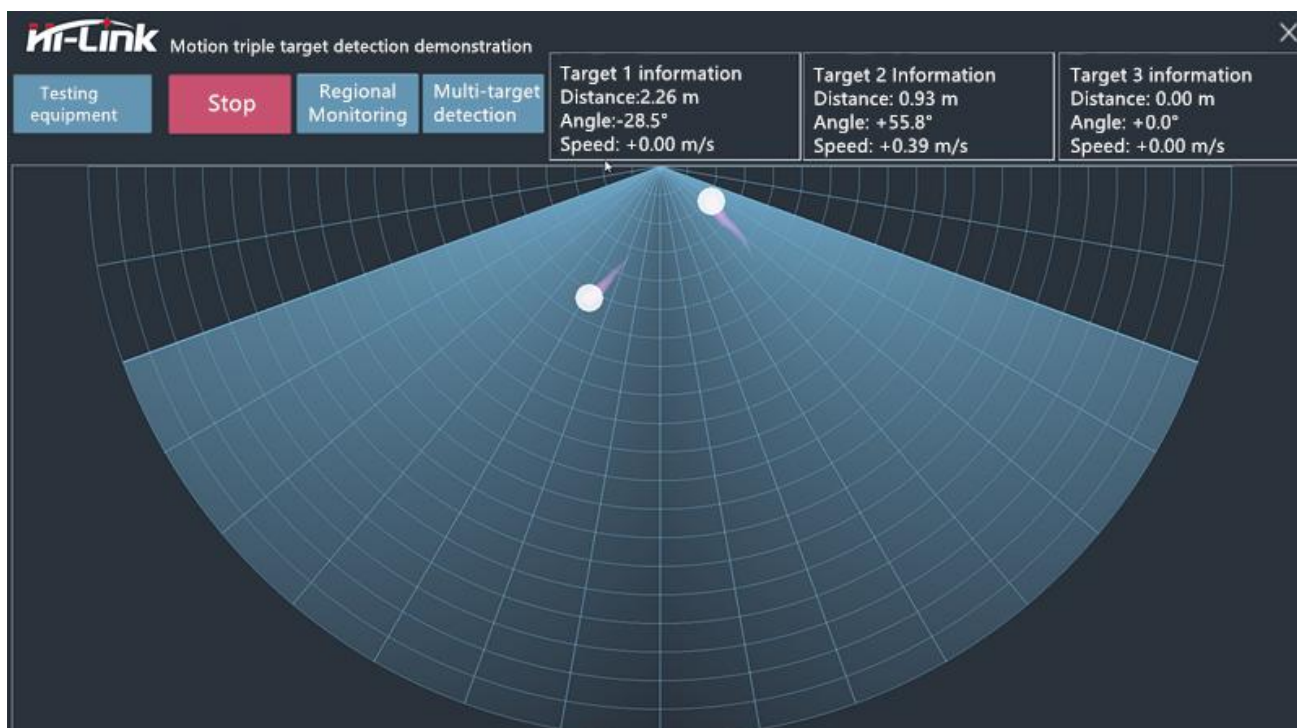

Figure 1 Effect of the upper computer function demonstration

2 Product features and advantages

2.1 Characteristics

- 24 GHz ISM band
- Integrated intelligent millimeter wave radar chip and intelligent algorithm firmware
- Precise motion target localization and tracking
- Longest detection range 6m
- Ultra-small module size: 15mm x 44mm
- Wall mounting
- Azimuth angle $\pm 60^\circ$, pitch angle $\pm 35^\circ$
- The ultimate cost-effective choice
- Multiple connection options with pin and socket interface

2.2 Solution advantages

LD2450 human body sensing module adopts 24GHz millimeter wave radar sensor technology, compared with other programs, has obvious advantages in human body sensing applications:

1. In addition to sensitive sensing of the movement of the human body, for the traditional program can not identify the micro-movement of the human body can also be sensitive to sense;

2. Good environmental adaptability, the induction effect is not affected by the surrounding environment such as temperature, brightness, humidity and light fluctuations;

3. Good shell penetration, can be hidden inside the shell work, no need to open holes in the product surface, improve the product aesthetics;

	Infrared Solutions	Visual Solutions	Ultrasonic	Laser Radar	Millimeter wave radar
Application Flexibility	●	●	●	●	●
Resistant to environmental influences (weather, light, etc.)	●	●	●	●	●
Detection speed	●	●	●	●	●
Detection Accuracy	●	●	●	●	●
Resolution	●	●	●	●	●
Directionality	●	●	●	●	●
Detection distance	●	●	●	●	●
Penetrating material capability	●	●	●	●	●
Size	●	●	●	●	●
Cost	●	●	●	●	●

● Good ● Normal ● Weak

Figure 2 Comparison between millimeter wave radar solution and other solutions

3 Application scenarios

The LD2450 motion target tracking sensor can accurately locate and track targets and is widely used in various AIoT scenarios, covering the following types:

Smart Home

Sensing the distance and angle of the human body, reporting the detection results for the main control module to intelligently control the operation of air conditioners, fans and other home appliances.

Smart Business

Position sensing, within the set position interval to identify the human body approaching or moving away, timely lighting or closing the screen.

Bathroom

Smart toilet accurately controls the automatic opening and closing of the toilet lid.

Smart Lighting

Identify and sense the human body, precise position detection, can be used in home lighting devices (sensor lamps, desk lamps, etc.).

4 Hardware description

4.1 Dimension

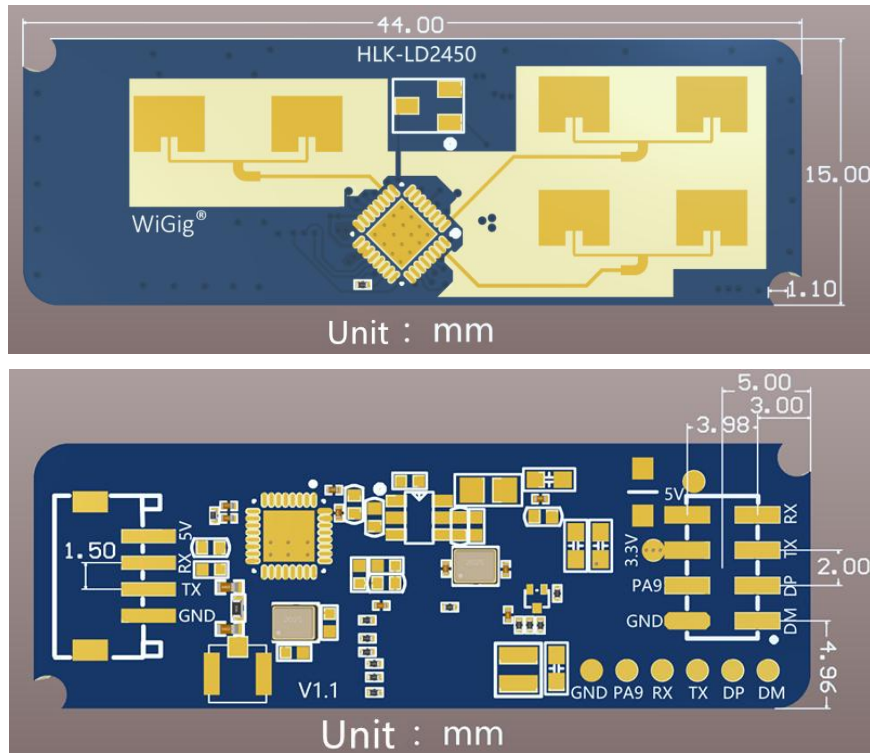
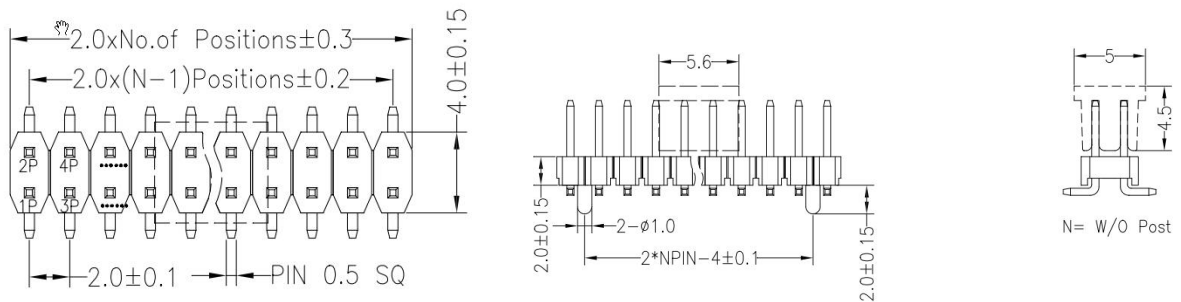

Figure 3 Module size diagram

The module provides two kinds of external interfaces, socket and pin, both of which have a serial port and a power supply port, so users can choose to use either of them as needed.

The dimensions of the pin interface are shown below:



Socket interface dimensions are shown below:

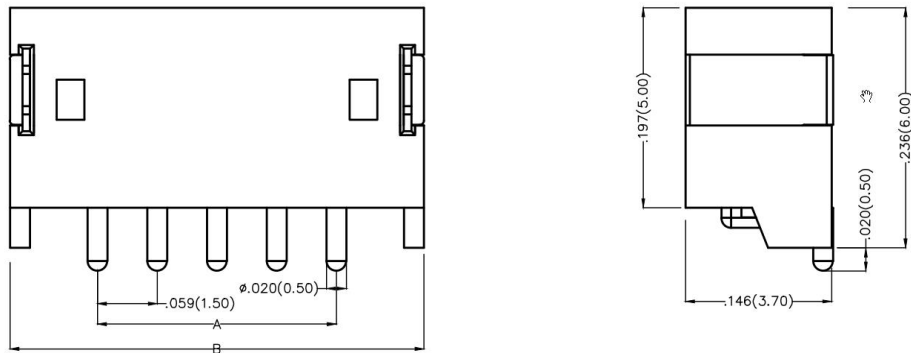

4.2 Pin definition:

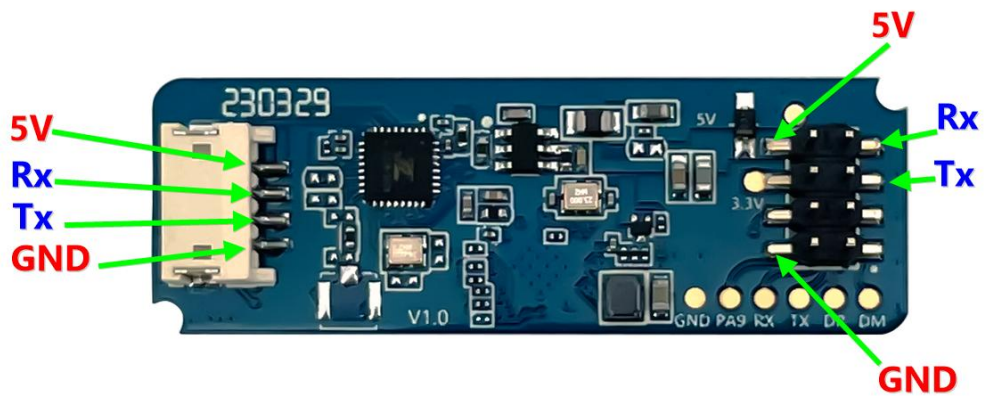

Figure 4 Module pin definition diagram

Pin	Function
5V	Power supply input 5V
GND	Power Ground
Tx	Serial port Tx pins
Rx	Serial port Rx pins

Table 1 Pin definition table

5 Use and configuration

5.1 Typical application circuits

LD2450 module directly through the serial port in accordance with the prescribed protocol for the output of the detection results data, the serial output data contains up to three targets position and speed and other information, the user can be used flexibly according to the specific application scenarios.

The module power supply voltage is 5V, and the power supply capacity of the input power supply is required to be greater than 200mA.

The module IO output level is 3.3 V. The default baud rate of the serial port is 256000, with 1 stop bit and no parity bit.

5.2 Description of the visualization upper computer

We provide LD2450's visualization upper computer demonstration software, which is convenient for users to experience the radar module's positioning and tracking effect on the target.

How to use the upper computer:

1. Use USB to serial tool to connect the module serial port correctly, module pin description please check [Table 1 pin definition table](#);
2. Open the ICLM_MTT.exe host tool software, click the detect device button, the host software automatically search the LD2450 module through the serial port;
3. After detecting the module, the host software will have the following prompt.

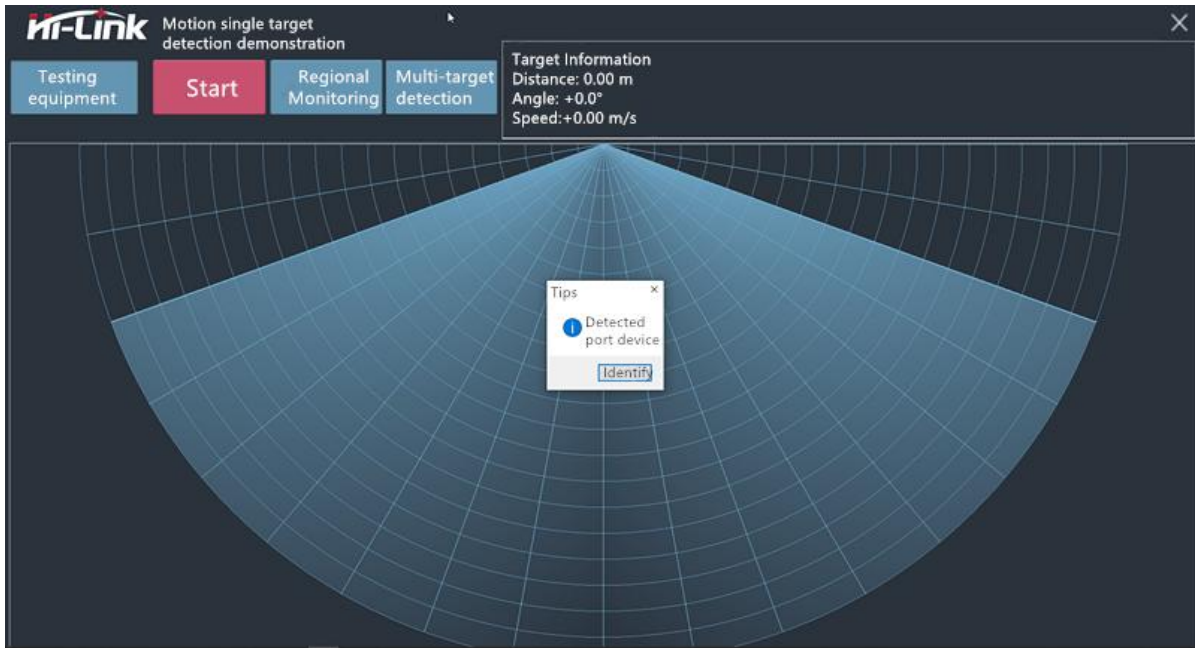

4. Then click the Start button, the host software will receive the detection data reported by the LD2450 module and display it on the software surface in real time.

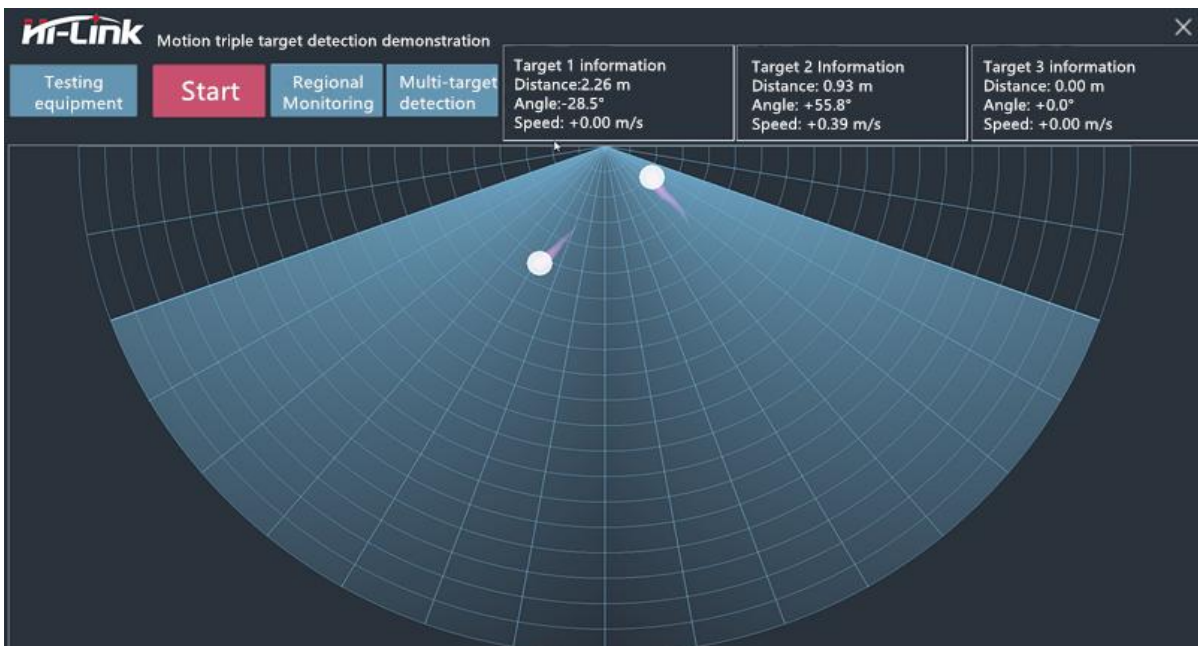

The display includes real-time positions of up to three targets on a sector map, distance, angle and speed information for each target.

0x00. The process of converting the data of target 1 into relevant information is demonstrated as follows:

$$\text{Objective 1 x-coordinate: } 0x0E + 0x03 * 256 = 782$$

$$0 - 782 = -782 \text{ mm}$$

$$\text{Objective 1 y-coordinate: } 0xB1 + 0x86 * 256 = 34481$$

$$34481 - 2^{15} = 1713 \text{ mm}$$

$$\text{Goal 1 speed: } 0x10 + 0x00 * 256 = 16$$

$$0 - 16 = -16 \text{ cm/s}$$

$$\text{Target 1 distance resolution: } 0x40 + 0x01 * 256 = 320 \text{ mm}$$

7 Installation method and detection range

The typical installation method of LD2450 is wall mounting, as shown in Figure 5, the farthest positioning tracking distance is 6m. wall mounting needs to consider the application scenario of shading and top interference, the recommended installation height range is 1.5~2m.

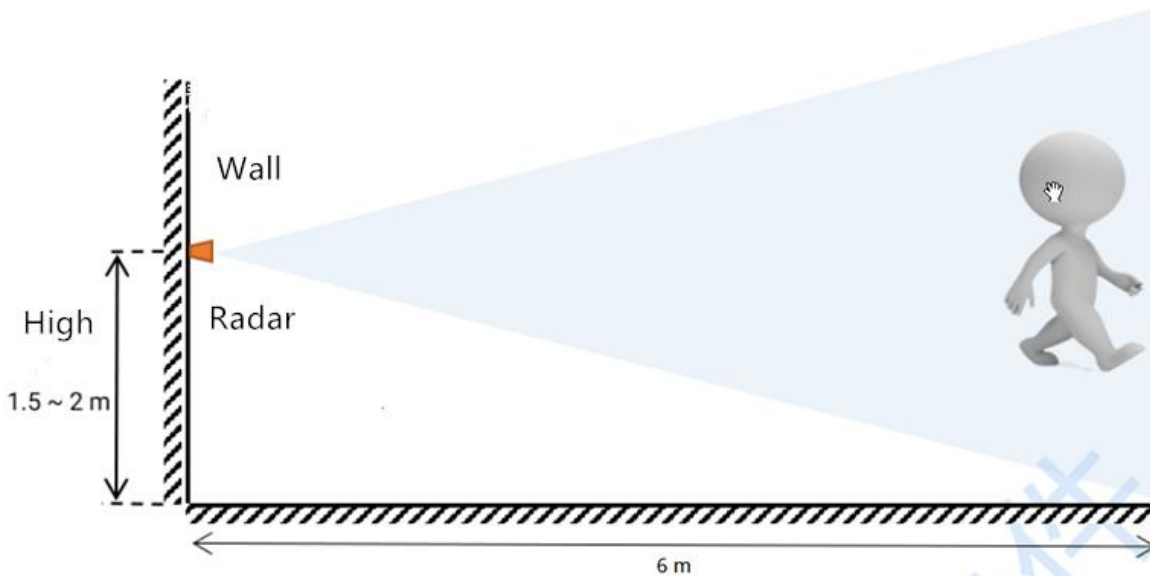

Figure 5 Diagram of wall mounting

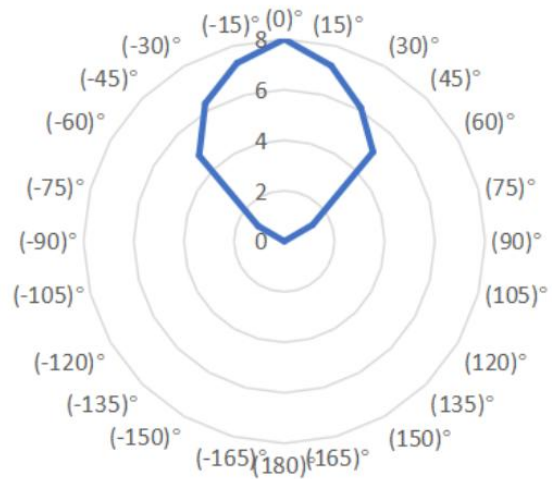
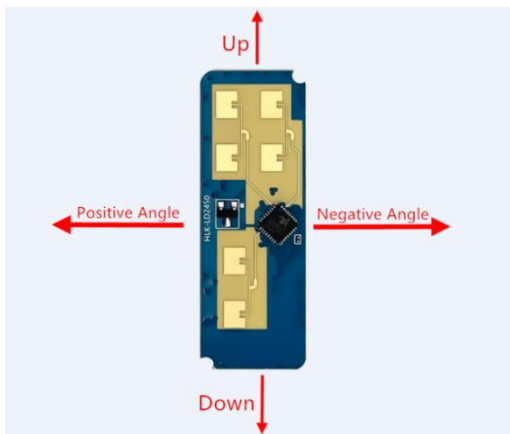

Figure 6 Radar wall mounting angle identification Figure 7 Schematic diagram of the tracking range when the radar is wall mounted (wall height 1.5 m)

Figure 7 shows the localization tracking range of this module at a wall height of 1.5 m. The test person was 1.75 m tall and of medium build. The detection angle range is $\pm 60^\circ$ centered normal to the radar antenna plane.

7.1 Installation instructions

Confirm minimum mounting clearance

If the radar needs to install the housing, the housing must have good wave transmission characteristics at 24 GHz and cannot contain metallic materials or materials that have a shielding effect on electromagnetic waves.

Installation environment requirements

This product needs to be installed in a suitable environment, the detection effect will be affected if used in the following environments:

- The presence of continuous movement of non-human objects in the sensing area, such as animals, continuously swinging curtains, large green plants facing the air outlet, etc.
- There is a large area of strong reflective objects in the sensing area, strong reflective objects will cause interference to the radar antenna
- When hanging wall installation, need to consider the indoor top of the air conditioning, electric fan and other external interference factors

Precautions for installation

- Try to ensure that the radar antenna is facing the area to be detected, and the antenna is open and unobstructed around
- Make sure the installation position of the sensor is firm and stable, the shaking of the radar itself will affect the detection effect
- To ensure that the back of the radar will not have object movement or vibration. Due to the penetrating nature of radar waves, the back flap of the antenna signal may detect the moving objects on the back of the radar. A metal shield or metal back plate can be used to shield the radar back flap to reduce the effect of objects on the back of the radar

- When multiple 24 GHz band radars are present, do not install them in the direction directly opposite to the beam, but as far away as possible to avoid possible mutual interference.

8 Performance and electrical parameters

Operating frequency band	24GHz~ 24.25GHz Comply with FCC, CE, Commission-free certification standards
Power supply requirements	DC 5V, power supply capacity >200mA
Average operating current	120 mA
Modulation method	FMCW
Interface	One UART
Target application	Detection and tracking of up to three targets
Detection distance	6m
Detection angle	$\pm 60^\circ$
Data refresh rate	10Hz
Sweep bandwidth	250MHz Compliant with FCC, CE, Commission-free certification standards
Ambient temperature	-40 ~ 85°C
Dimension	15mm x 44 mm

Table 4 Table of performance and electrical parameters

9 Antenna cover design guide

9.1 Effect of antenna cover on millimeter wave sensor performance

- Radar waves are reflected on the radome boundary
 1. The total power radiated or received by the radar is lost
 2. The reflected wave enters the receiving channel, affecting the isolation between the transmitting and receiving channels
 3. The reflection may make the antenna's standing wave worse, further affecting the antenna gain
- Radar wave propagation in the medium will occur loss, theoretically the higher the frequency loss will be greater
- The electromagnetic wave will be refracted to a certain degree when passing through the medium
 1. Affect the radiation direction map of the antenna, which in turn affects the coverage of the sensor

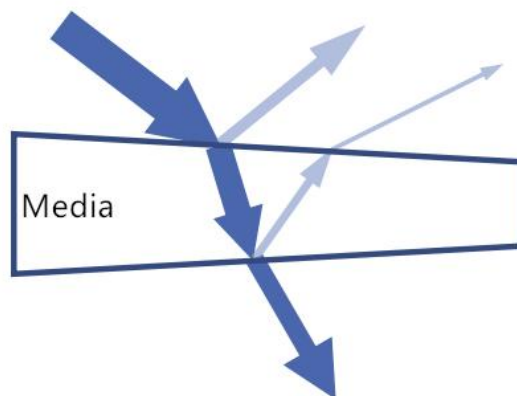

9.2 Antenna cover design principles

Structural shape of the antenna cover

- Smooth and flat surface, uniform thickness. Such as flat or spherical surface, not uneven
- If there is surface coating, it cannot contain metal or conductive material

- Above the antenna, the antenna surface is parallel to the antenna surface

The height of the antenna to the inner surface of the radome H

- The ideal height is an integer multiple of the half-wavelength of electromagnetic waves in the air

- $H = \frac{m}{2} * \frac{c_0}{f}$, where m is a positive integer, c_0 is the vacuum speed of light, f is the working center frequency.

- For example, 24.125GHz center frequency, its half-wavelength in the air is about 6.2mm

The thickness of the antenna cover D

- The ideal thickness is an integer multiple of the half-wavelength of the electromagnetic wave in the medium

- $D = \frac{m}{2} * \frac{c_0}{f\sqrt{\epsilon_r}}$, where m is a positive integer, ϵ_r is the relative dielectric constant of the radome material

- For example, an ABS material $\epsilon_r = 2.5$, its half wavelength of about 3.92mm

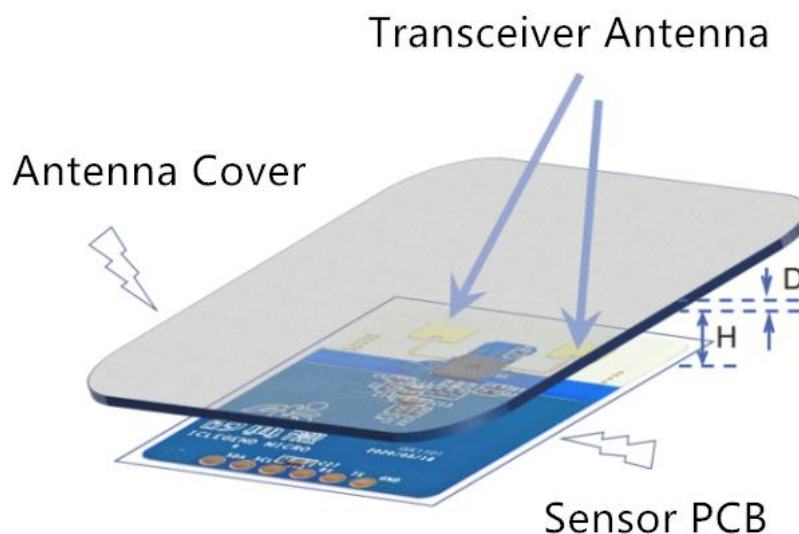

9.3 Common materials

Before design, understand the material and electrical characteristics of the radome

- The table on the right is for reference only, Please confirm the actual value with the supplier

The height of the antenna to the inner surface of the radome H

- When space allows, 1 or 1.5 times Wavelength is recommended.

- For example, 12.4 or 18.6mm is recommended for 24.125GHz
- Error control: $\pm 1.2\text{mm}$

The thickness of antenna cover D

- Recommended half wavelength, error control $\pm 20\%$
- If the thickness requirement of half wavelength cannot be met
- Low ϵ_r material is recommended
- Thickness recommended 1/8 wavelength or thinner
- The effect of inhomogeneous materials or multi-layer combination of materials on radar performance is recommended for experimental adjustment during design

Common material properties (based on 24.125GHz)

Medium	ϵ_r Typical value	Half wavelength (mm)	1/8 wavelength (mm)	1/10 wavelength (mm)
Air	1.00	6.20	1.55	1.24
ABS1	1.50	5.06	1.27	1.01
ABS2	2.50	3.92	0.98	0.78
PC material	3.00	3.58	0.89	0.72
PMMA acrylic 1	2.00	4.38	1.10	0.88
PMMA acrylic 2	5.00	2.77	0.69	0.55
PVC hard	4.00	3.10	0.78	0.62
PVC soft	8.00	2.19	0.55	0.44
High density PE	2.40	4.00	1.00	0.80
Low density PE	2.30	4.09	1.02	0.82
Quartz glass	5	2.77	0.69	0.55

Table 5 Common material properties of antenna covers

10 Revision record

Date	Version	Modified content
2023-5-10	1.00	Initial Version

11 Technical support and contact information



Shenzhen Hi-Link Electronic Co.,Ltd

Address: 1705, 17/F, Building E, XingheWORLD, Minle Community, Minzhi Street,
Longhua District, Shenzhen

Tel: 0755-23152658/83575155

Website: www.hlktech.com

