

# **Level measurement radar module**

## **LD8001 Data Sheet**

**2023.09**

**Shenzhen Hi-Link Electronic co., Ltd**

# Content

<b>1. PRODUCT DESCRIPTION</b> .....	<b>1</b>
<b>2. PRODUCT CHARACTERISTICS</b> .....	<b>1</b>
<b>3. APPLICATION SCENARIOS</b> .....	<b>1</b>
<b>4. ELECTRICAL CHARACTERISTICS &amp; PARAMETERS</b> .....	<b>1</b>
4.1 FUNCTIONAL CHARACTERISTICS .....	1
4.2 ELECTRICAL CHARACTERISTICS .....	1
4.3 RF CHARACTERIZATION .....	2
<b>5. HARDWARE DESCRIPTION</b> .....	<b>2</b>
5.1 EXTERNAL DIMENSION .....	2
5.2 PIN DEFINITIONS .....	3
5.3 MODULE PERIPHERAL REFERENCE DESIGN .....	3
5.4 STARTUP CONFIGURATION .....	4
<b>6. USE &amp; CONFIGURATION</b> .....	<b>4</b>
6.1 TYPICAL APPLICATION CIRCUIT .....	4
6.2 GUI VISUALIZATION TOOL APPLICATIONS .....	4
6.3 OTA UPGRADE .....	5
6.4 INSTALLATION AND SENSING RANGE .....	5
<b>7. CAVEAT</b> .....	<b>6</b>

# 1. Product Description

LD8001 is a radar sensing module developed based on ADT3102 chip, with monolithic integration of 76-81GHz RF transceiver system, 1T1R PCB high gain antenna, 1MB flash, radar signal processing unit, ARM® Cortex®-M3 core. This module is based on FMCW signal processing mechanism, combined with radar signal processing algorithms, to realize high-precision ranging, suitable for high-precision liquid level and material level measurement.

## 2. Product Characteristics

- Radar Detection Based on FMCW FM Continuous Wave Signal
- Measuring distance up to 15m
- Highly accurate continuous measurement with an error of +/-5mm
- Antenna -3dB Beam Angle 100° Horizontal, 80° Tilt
- Support SPI, Uart, I2C standard communication interface
- Compact size, R=19.5mm, pin header connection
- Flexibility to add lenses to change the antenna angle
- Unaffected by temperature, humidity, noise, airflow, dust, light and other environmental influences

## 3. Application Scenarios

- ◇ Industrial level measurement
- ◇ Sewer level detection
- ◇ Non-contact measurement of medical acidic and alkaline liquids
- ◇ Fuel tanks, IBC tonne drums, viscous liquid measurement

## 4. Electrical Characteristics & Parameters

### 4.1 Functional characteristics

Parameter content	Min.	Typ.	Max.	Unit.
Maximum range			15	m
Measurement blindness		14		
Measurement accuracy		+/-5		mm
Response time		200		ms

### 4.2 Electrical characteristics

Operating parameters	Min.	Typ.	Max.	Unit.
Work voltage (VCC)	3.5	3.3	3.5	V
Work current (ICC)		135	600	mA
Work temperature (TOP)	-20		85	°C
Storage temperature (TST)	-40		85	°C



## 5.2 Pin Definitions

Pins	No.	Pin name	Description	Note
J1	1	SCL1	IOPAD_P17/IIC1_SCL	
	2	SDA1	IOPAD_P18/IIC1_SDA	
	3	P19	BOOT1	Internal pull-up
	4	GND	GND	
	5	P12	BOOT0	Internal pull-up
J2	1	3V3	3.3V power input	Debugging interface
	2	DI0	SWD Debug Signal	
	3	SWCLK	SWD Debug Clock	
	4	GND	GND	
	5	AIO1	Analog Inputs	The analog IO voltage should not exceed 1.35V, 0.5-0.8V is a non-linear region and is not recommended.
J3	1	3V3	3.3V power input	Communication interface with host computer
	2	GND	GND	
	3	TX2	IOPAD_P20/UART2_TX	
	4	TX0	TTL serial port 0 's TX	
	5	RX0	TTL serial port 0 's RX	
J4	1	CS	EFLASH_CSN	
	2	CLK	EFLASH_SCLK	
	3	MOSI	EFLASH_MOSI	
	4	TX1	IOPAD_P10/UART1_TX	
	5	RX1	IOPAD_P11/UART1_RX	
J5	1	CS1	IOPAD_P14/SPI1_CSN	
	2	SCLK1	IOPAD_P13/SPI1_SCLK	
	3	MOSI1	IOPAD_P16/SPI1_MOSI	
	4	MISO1	IOPAD_P15/SPI1_MISO	
	5	P28	IOPAD_P28/VGA1_IOUTN	

## 5.3 Module peripheral reference design

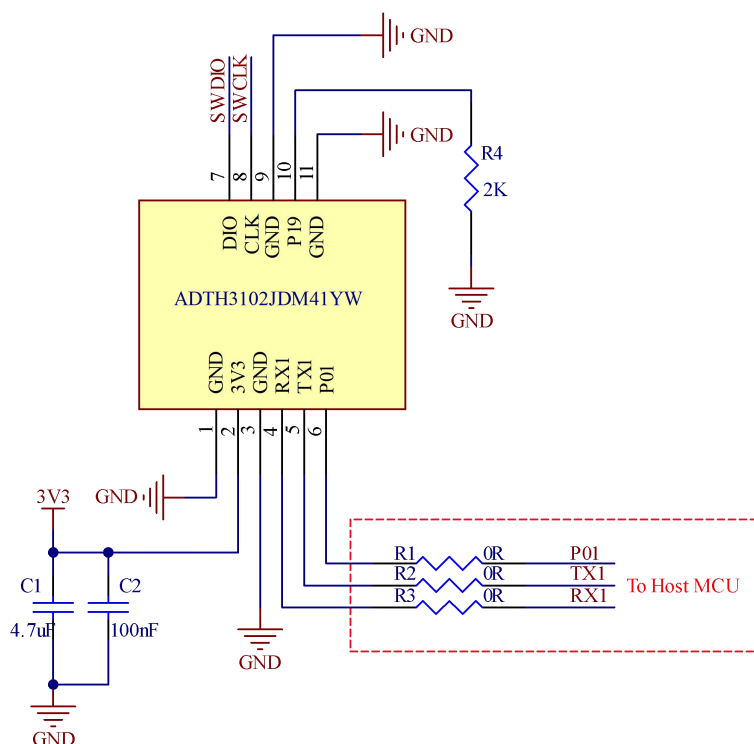

## 5.4 Startup configuration

	BOOT1	BOOT0	Note
Configuration level	0	1	In-module flash startup
Pin number	J1-3	J1-5	

\* BOOT1, BOOT0 modules have internal pull-ups. BOOT1 must be held low before the module can be started.

## 6. Use & Configuration

### 6.1 Typical application circuit

LD8001 module can directly use UART0 to output detection results in accordance with the specified protocol, the serial data contains distance information, the user according to the specific application scenarios for flexible use.

Module power supply 3.3V, input power supply capacity requires more than 1A.

### 6.2 GUI visualization tool applications

#### 1. Device connection

- 1) Select the serial port number corresponding to the connection
- 2) Set the baud rate to 115200
- 3) Click the [Connect] button
- 4) Click the [Distance view] button to enter the distance view page, the green box shows the distance information. The lower System Log window prints the message information.

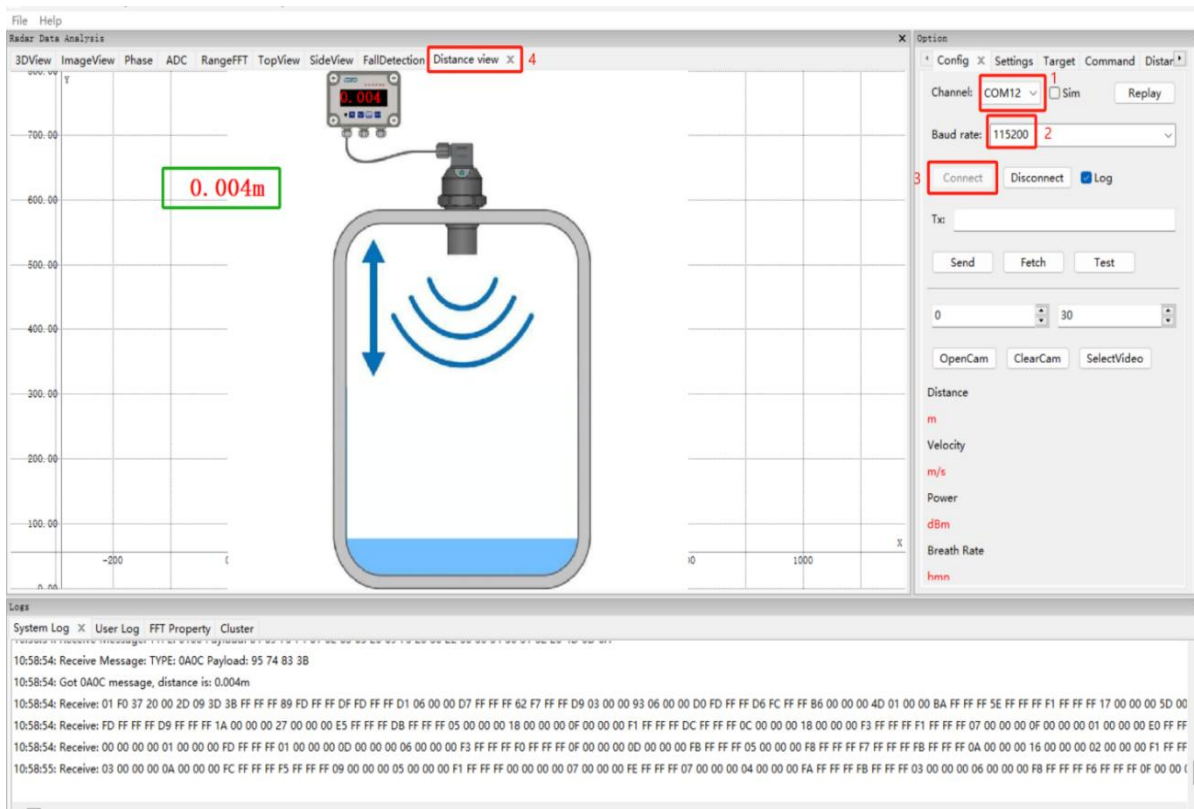

## 2. FFT information view

Click the [RangeFFT] button to view the FFT information.

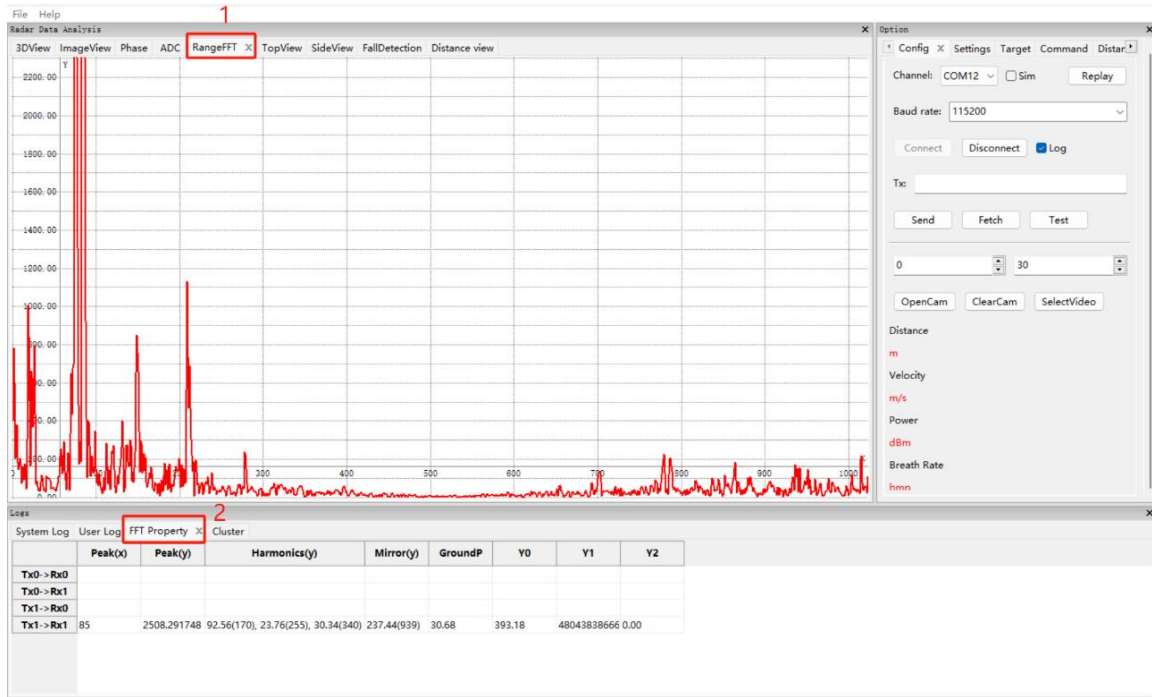

## 6.3 OTA upgrade

Refer to “OTA Upgrade Tool User Manual\_V1.0”.

## 6.4 Installation and sensing range

Mounted on the lid of the liquid container, in order to ensure the accuracy of the measurement, the installation is as close as possible to the center of the container lid, the antenna parallel to the liquid surface to be measured.

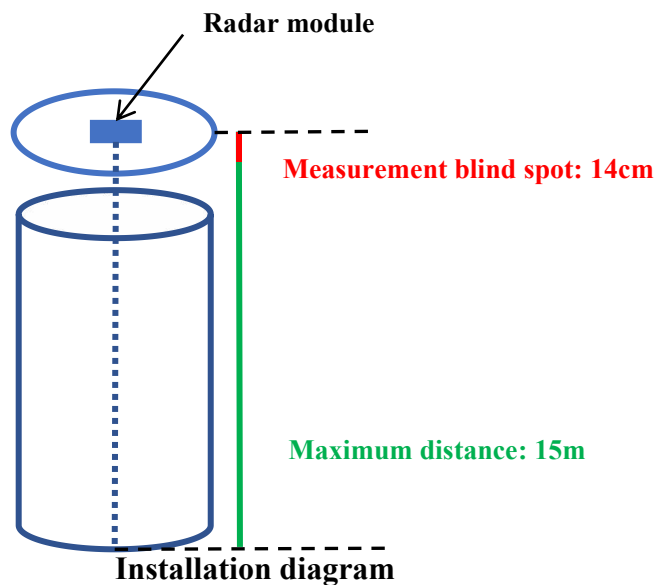

## 7. Caveat

1. The detection distance of the radar module is related to the target RCS and environmental factors, and the effective detection distance may change with the environment and the target, so it is normal that the effective detection distance fluctuates in a certain range.

2. The radar module has extremely high power requirements, requiring an input voltage of 3.1~3.5V, power supply ripple  $\leq 50\text{mV}$ , and current  $\geq 1\text{A}$ . If a DCDC power supply is used, the switching frequency is required to be no less than 2MHz.



## Shenzhen Hi-Link Electronic Co.,Ltd

Address: 1705, 17/F, Building E, Xinghe WORLD, Minle Community, Minzhi Street, Longhua District, Shenzhen

Tel: 0755-23152658/83575155

Email: [sales@hlktech.com](mailto:sales@hlktech.com)

Website: <https://www.hlktech.net/>